



EVOLUÇÃO METALÚRGICA



EVOLUÇÃO METALÚRGICA



APRESENTAÇÃO DA EMPRESA

A Evolução Metalúrgica e Implementos foi fundada em 2011, e está localizada na cidade de Itumbiara, Goiás, com área total de 29.500m², e capacidade de atendimento em todo o país.

Atuamos com excelência na área metalúrgica para os segmentos: industrial, agrícola, automobilístico, estrutura metálica e energia, e estamos preparados para atender os diversos tipos de projetos que contemplam peças, chaparia e usinagem.

Dispomos de máquinas e equipamentos modernos de alta qualidade e desempenho, possibilitando os mais diversos trabalhos, como: projetos industriais, serviços de usinagem, corte, dobra, fabricação de peças industriais, afiações de ferramentas, serviços de montagens industriais, entre outros.

Contamos com uma equipe de colaboradores especializados e com uma excelente infraestrutura. Somos uma empresa sólida e arrojada e estamos em constante evolução, através da aquisição de equipamentos modernos, formação profissional de nossa equipe e implantação das melhores práticas de mercado no que tange processos produtivos e de gestão para atender todas as necessidades de nossos clientes.

ÁREA FABRIL

A Evolução Metalúrgica e Implementos coloca à disposição de seus clientes os mais modernos equipamentos e maquinários para prestar serviços com qualidade e excelência.

Oferecemos os mais variados serviços para suprir toda e qualquer demanda do mercado:



- ✓ Caldeiraria em geral
- ✓ Manutenção e Montagem Industrial
- ✓ Corte e Dobra
- ✓ Serviços de Solda
- ✓ Fabricação e Venda de Peças
- ✓ Manutenção de Equipamentos Agrícolas e Rodoviários
- ✓ Montagem de Tubulações
- ✓ Usinagem em geral
- ✓ Serviços de Munck
- ✓ Jato de Granalha
- ✓ Pinturas Industriais





EVOLUÇÃO METALÚRGICA

CORTE E DOBRA

Realizamos cortes a plasma com alta definição em chapas de aço de 1 a 50mm



Plasma 12m



Plasma 6m



Guilhotina

Realizamos serviços de corte em chapas de aço de 1 a 10mm com 3000mm de comprimento.



EVOLUÇÃO METALÚRGICA

CORTE E DOBRA

Oferecemos serviços de corte em cantoneiras e perfis retangulares com espessura de até 9,5mm.



Corte a Laser

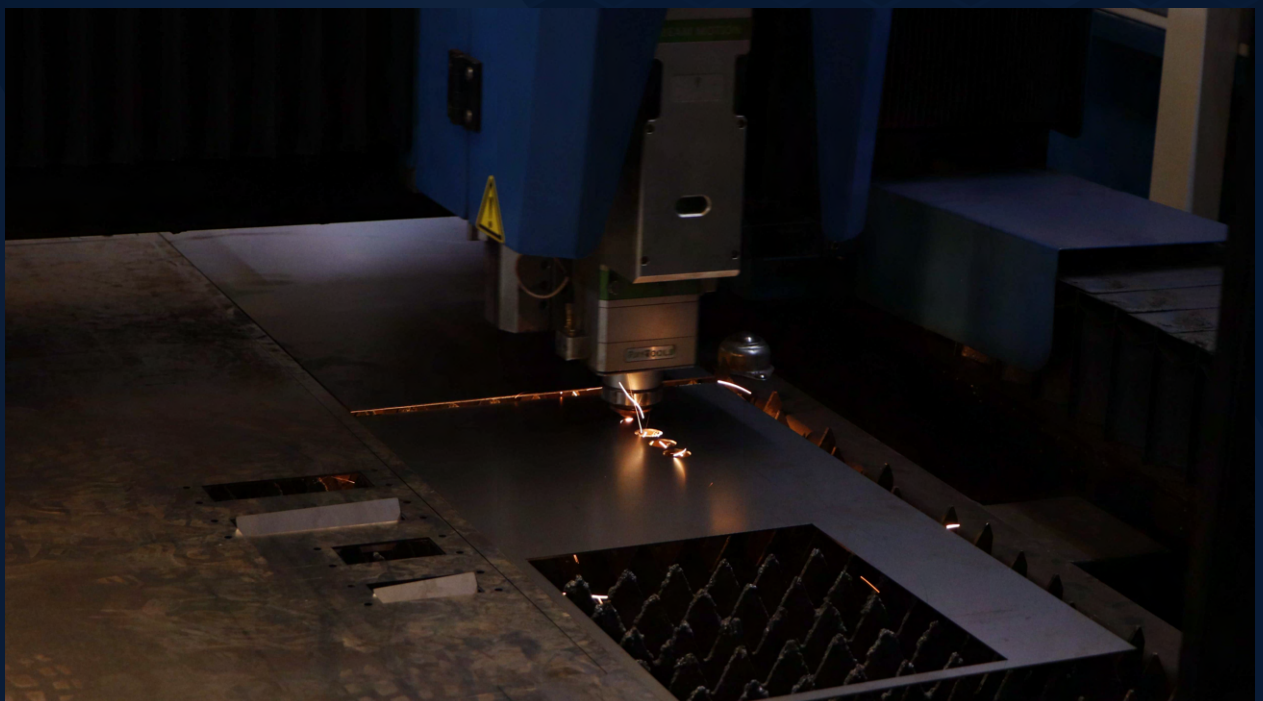



EVOLUÇÃO METALÚRGICA

CORTE E DOBRA



Dobradeira 6m



Dobradeira 3m

Tecnologia em serviço de dobra com capacidade de:

- ✓ 1,5 mm a 10mm com 6 metros de comprimento;
- ✓ 1,5 a 12,7 mm com 3 metros de comprimento.





EVOLUÇÃO METALÚRGICA

CORTE E DOBRA

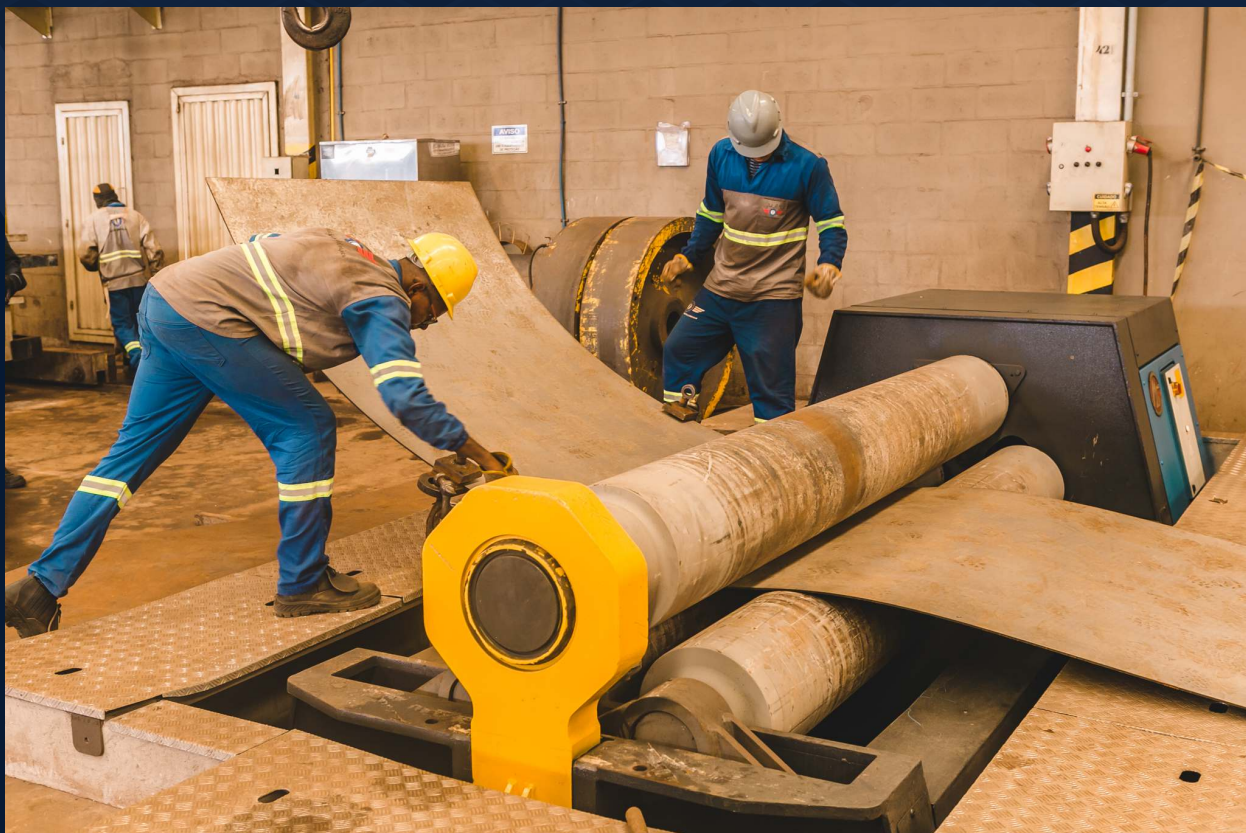

Calandra 3000 X 32mm e Calandra 1500 X 6,35mm



Evolução Metalúrgica

MONTAGENS INDUSTRIAIS



Tecnologia em serviços de solda em aço carbono e aço inox, além de solda MIG, solda TIG e eletrodo revestido.



Oferecemos soluções em serviços de caldeiraria leve e pesada.

MONTAGENS INDUSTRIAIS



CALDEIRARIA E MONTAGEM INDUSTRIAL

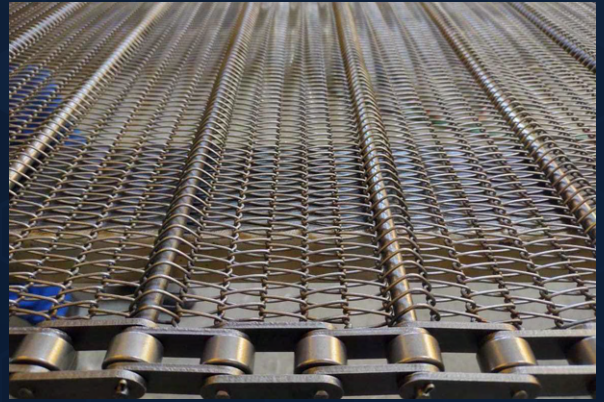

Prestação de serviços de manutenção em mesa alimentadora; esteira metálica; moenda. Prestação de serviços de manutenção no sistema de lavador de gás

CALDEIRARIA E MANUTENÇÃO EM CALDEIRAS INDUSTRIAIS

Oferecemos serviços e manutenção em Caldeiras Industriais que visam assegurar o pleno funcionamento de todos os componentes, permitindo que o máximo proveito seja obtido cotidianamente.



PINTURA INDUSTRIAL

Oferecemos serviços de pintura líquida padrão e especiais e pintura eletrostática



PINTURA ELETROSTÁTICA



CABINE DE PINTURA LÍQUIDA



JATO DE GRANALHA

Tecnologia de jateamento em peças de 0 a 6 metros x 2,5 metros de largura

PROJETOS

Desenvolvimento e criação de projetos para da fabricação de peças e implementos de acordo com a necessidade de cada cliente.

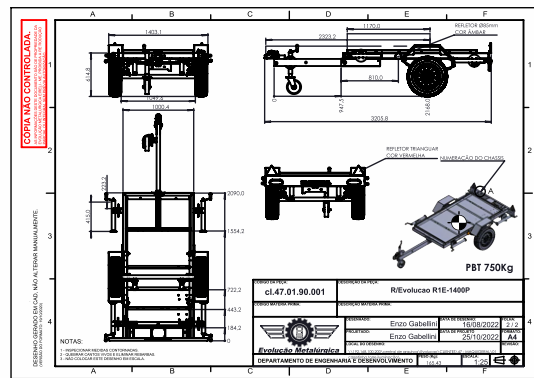
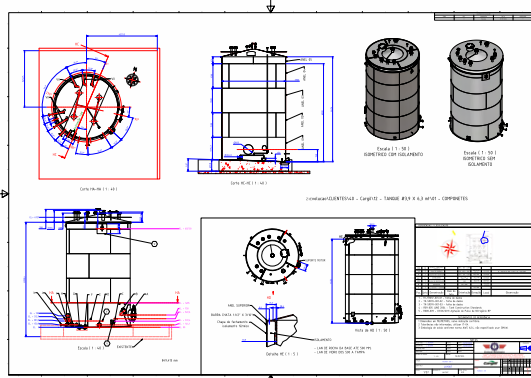
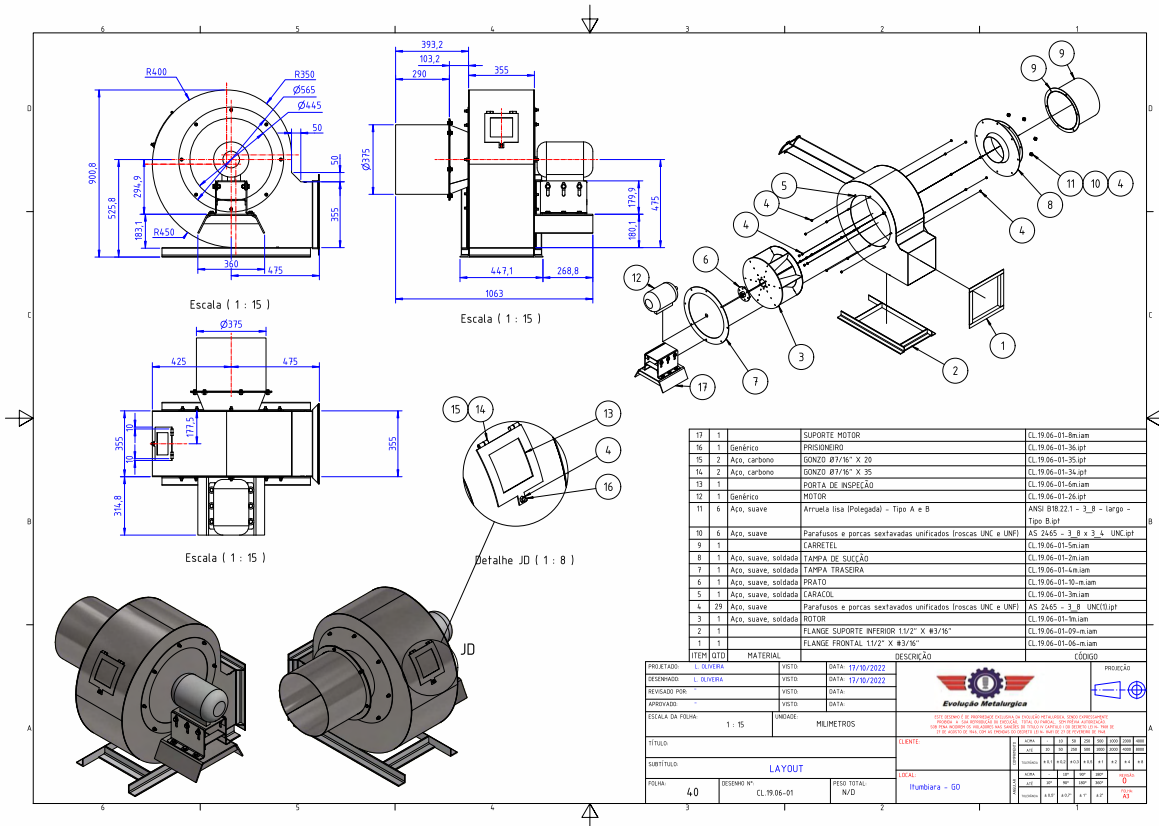

CENTRO DE USINAGEM

A EVOLUÇÃO dispõem de um centro de usinagem capaz de atender aos mais variados tipos de serviços

- ✓ Usinagem em torno CNC
- ✓ Serviços de fresa
- ✓ Afição de ferramentas
- ✓ Usinagem com torno convencional





EVOLUÇÃO METALÚRGICA

CENTRO DE USINAGEM

Venha conhecer nossa estrutura que colocamos a sua disposição para melhor atender as suas necessidades



MANUTENÇÃO DE IMPLEMENTOS AGRÍCOLAS E RODOVIÁRIOS

Serviços especializados em:

✓ **Montagem e manutenção industrial**



MANUTENÇÃO DE IMPLEMENTOS AGRÍCOLAS E RODOVIÁRIOS

- ✓ Reforma de carretas canavieiras
- ✓ Reforma em transbordo



MANUTENÇÃO DE IMPLEMENTOS AGRÍCOLAS E RODOVIÁRIOS

✓ Reforma de implementos agrícolas
Entre outros serviços que possa atender a sua empresa



FABRICAÇÃO PRÓPRIA



Carroceria Caminhão Muncck



Carreta de Plataforma



EVOLUÇÃO METALÚRGICA

FABRICAÇÃO PRÓPRIA



Plataforma Prancha



Carreta Tanque

FABRICAÇÃO E VENDA DE PEÇAS



Estruturas Metálicas

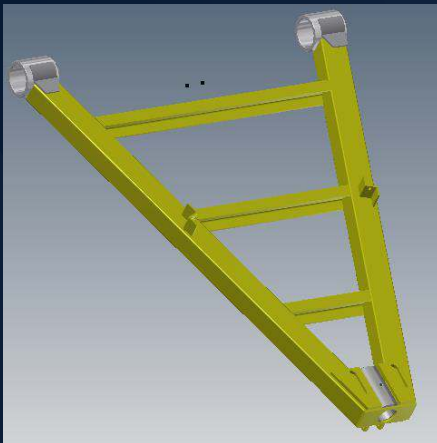

Cabeçalhos Diversos



Suporte Ponteira



Peças Diversas - Usinagem



CAMINHÃO MUNCK

Disponibilizamos aos nossos clientes
locação de Caminhão Munck.



FROTA PRÓPRIA

Contamos com frota própria para garantir rapidez e segurança na entrega dos serviços.





EVOLUÇÃO METALÚRGICA



EVOLUÇÃO METALÚRGICA



@evolucao_metalurgica



contato@evolucaometalurgica.ind.br



(64) 3433-2081
(WhatsApp)



@EvolucaoImplementosOficial



Rua V Primária 01, S/N, Qd 4
Lote 7-14, Distrito Agro Industrial
(DIAGRI) Itumbiara - GO



evolucaometalurgica.ind.br